

# LCD Monitor Arm // Installation Manual

Product name: Full motion slat rail gas arm

Model no. BS115

## Product Specification

Sketch											
Item	Monitor size	Weight range (kg)	Lift(mm)	Tilt	Swivel	Pivot	VESA	Packing size (mm)	N.W(kg)	G.W(kg)	Clamp size (mm)
Specification	≤30°	2-10	340	+75°~ -30°	±90°	±90°	75*75	Inner: 520*140*110	Inner: 1.8	Inner: 2.2	38~55
		8-20					100*100	Outer: 535*155*350	Outer: 5.4	Outer: 7	

## Product Size

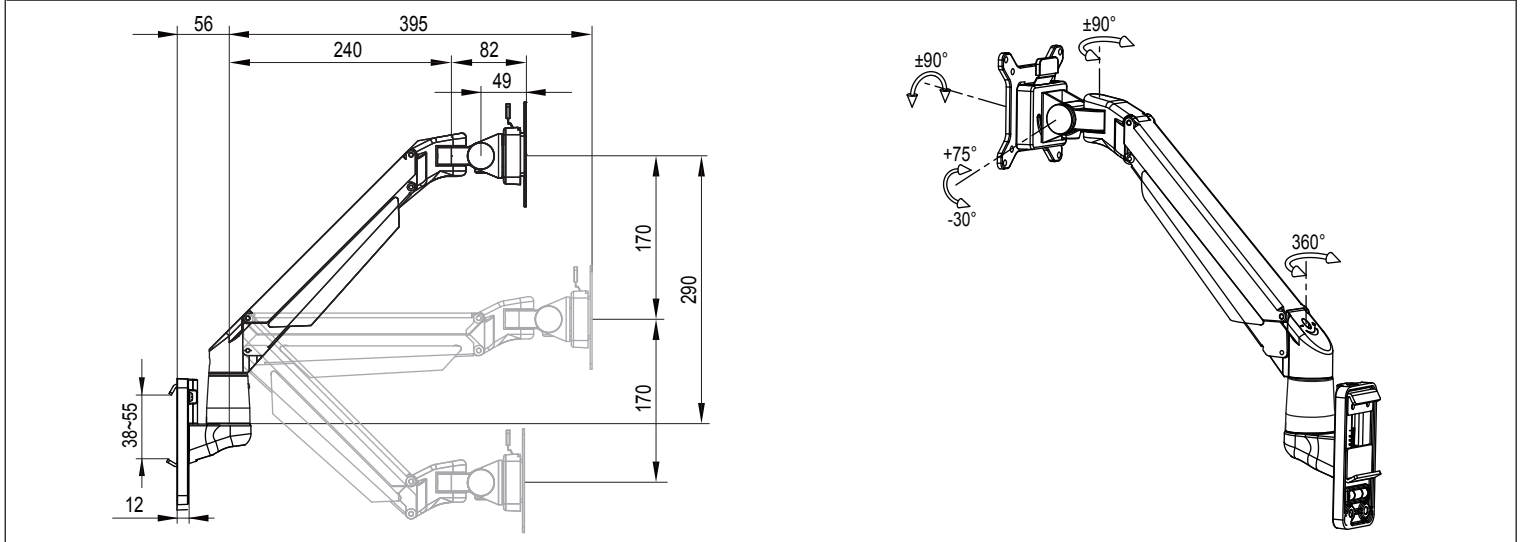

## Installation of Slat Rail-fixed Base

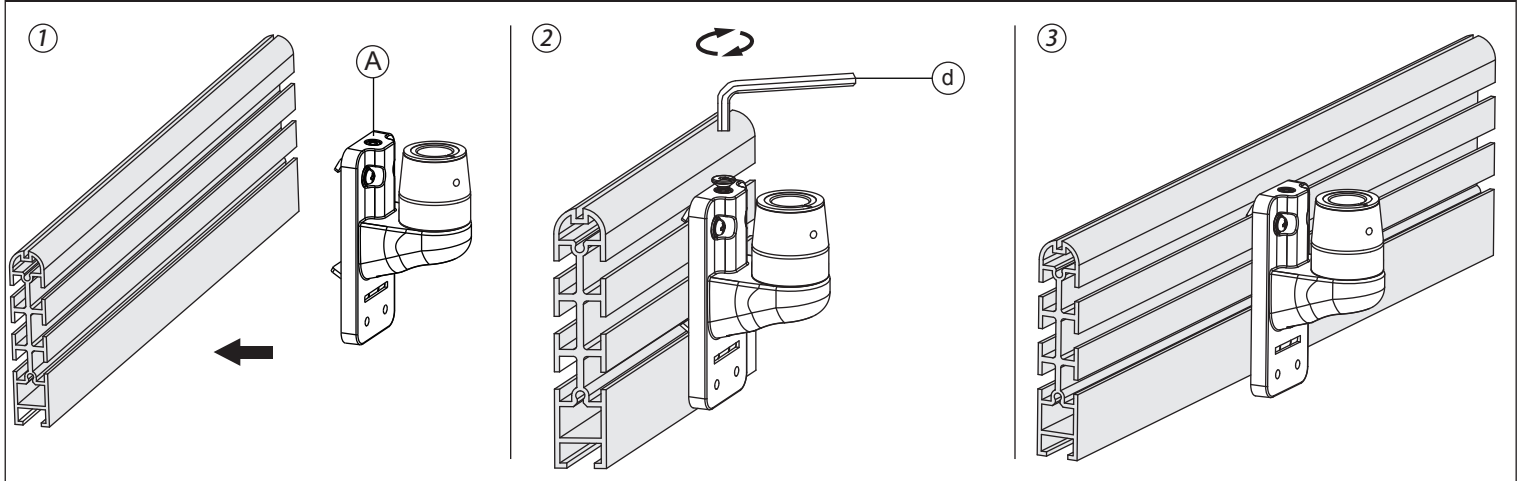

## Install Procedure

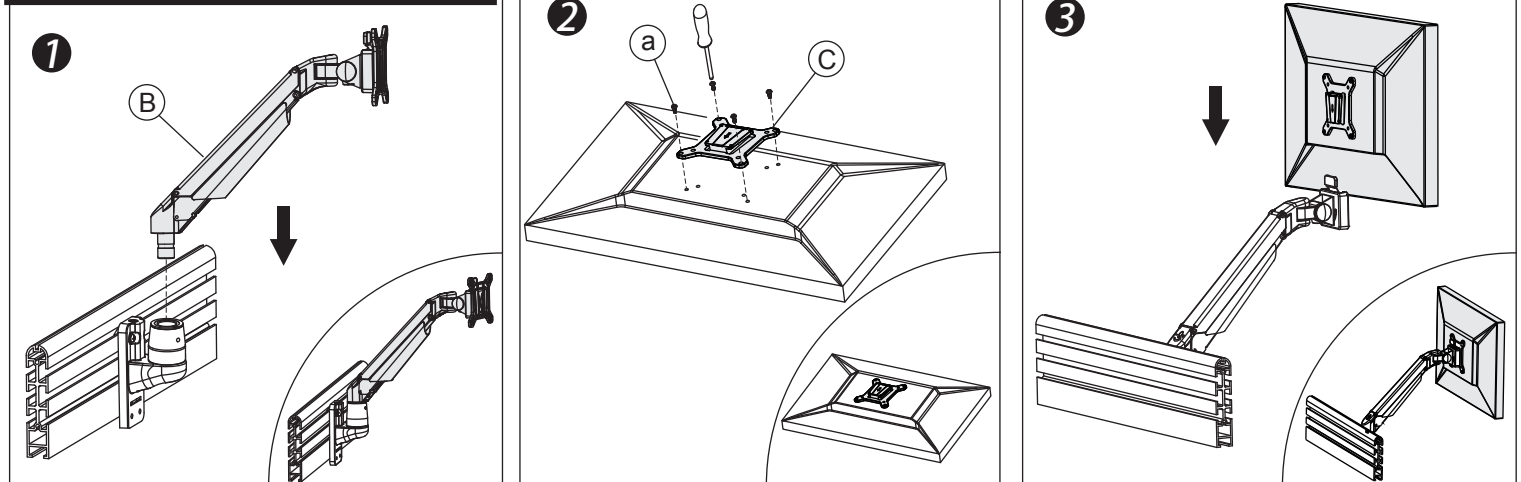

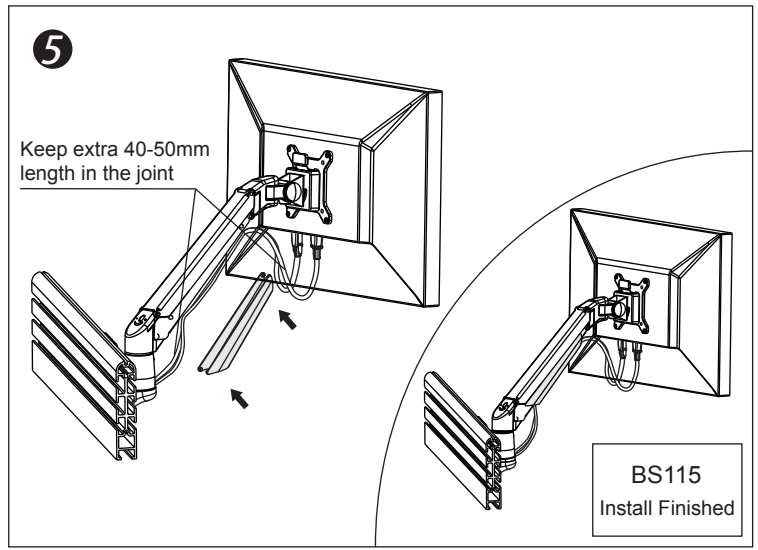
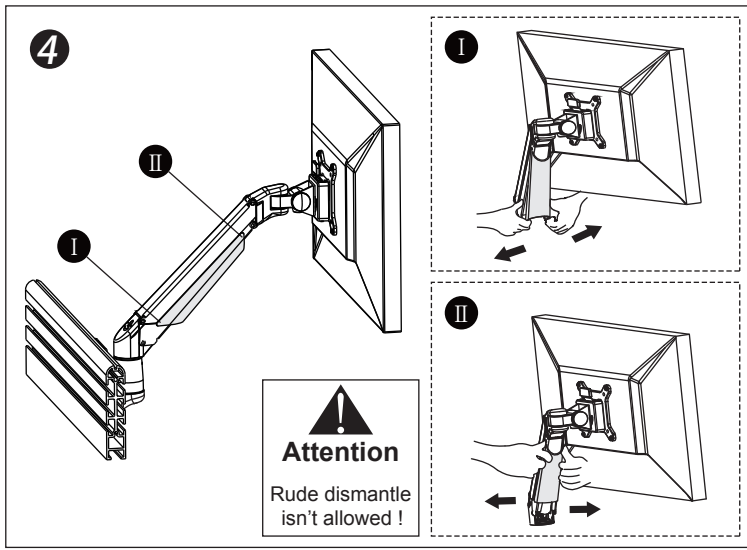

**Adjust Procedure**

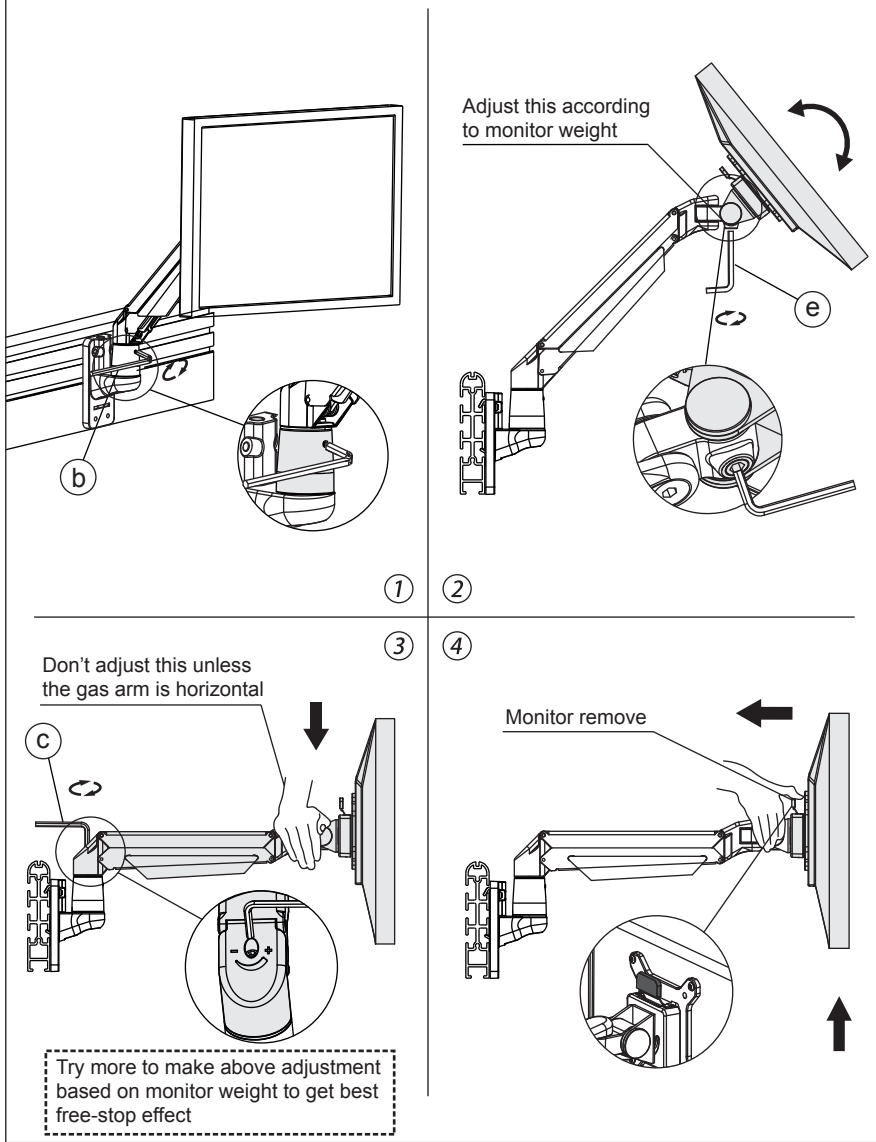

**Module List**

No.	Sketch	Specs	Quantity
A			1
B			1
C			1

**Part List**

No.	Sketch	Specs	Quantity
a		M4x12	4
b		M3	1
c		M4	1
d		M5	1
e		M6	1